



AXOMIX

600
750
800
1000
1500
2000



AXOMATIC[®]
group

TUBE FILLING, CARTONING AND PROCESS SOLUTIONS



AXOMATIC Filling and Process Solutions leader da sempre nel settore delle macchine intubatrici, mescolatori sottovuoto e macchine di processo è presente sui più competitivi mercati mondiali ed ha macchine installate nelle più importanti società cosmetiche, farmaceutiche ed alimentari.

Premiata dal costante successo dei propri prodotti, dotati delle più avanzate tecnologie, quali anticipatori di domande sempre più sensibili ai contenuti dell'innovazione e della semplicità di utilizzo e cambio di formato.

Il servizio post vendita qualifica anche sotto il profilo commerciale, l'eccellenza della società Axomatic, verso il cliente.



Axomatic has always been a leader in the filling and process solution sector, is present in the most competitive and important world markets and its machines are installed in the most important cosmetic, pharmaceutical and food industries.

The company is proud of the constant success of its product, which are equipped with the most advanced technology and anticipate increasingly more detailed requests concerning innovation.

Even under the sales profile, the after-sales service is proof of the excellent service that Axomatic gives its clients.



AXOMATIC Filling and Process Solutions war schon immer eines der führenden Unternehmen im Bereich der Tubenfüll- und -verschleißmaschinen sowie der Misch- und Homogenisieretechnik. Die AXOMATIC Maschinen sind auf allen wichtigsten Weltmärkten in der kosmetischen, pharmazeutischen, chemischen und Nahrungsmittelindustrie im Einsatz und durch ihr attraktives Preis-/Leistungsverhältnis ueberaus konkurrenzfaehig.

AXOMATIC ist durch die konstante Qualität und Zuverlässigkeit seiner Produkte geprägt, die stets über modernste Technologien verfügen und bei denen auf Innovation größten Wert gelegt wird. So ist man bei AXOMATIC auch stets bereit, auf Sonderwünsche des Kunden einzugehen.

Ein weiterer wesentlicher Punkt, den man bei AXOMATIC nie außer acht gelassen hat, ist der Kundenservice, der durch ein weltweites Netz von Vertretungen und Servicetechnikern gewährleistet wird.

AXOMIX

- Axomix con turbina azionata dal basso e ricircolo del prodotto
- Axomix with bottom driven turbine and external product recirculation

600
750
800
1000
1500
2000



- Axomix con turbina azionata dal basso
- Axomix with bottom driven turbine



- Fusori da 5 lt. a 2000 lt.
- Pre-melters from 5 up to 2000 lt.



- Pale contro-rotanti
- Contra-rotating blades



- Valvole per carico / scarico prodotto
- Valves for product suction and discharge



- Turbina rotore statore
- Turbine rotor stator

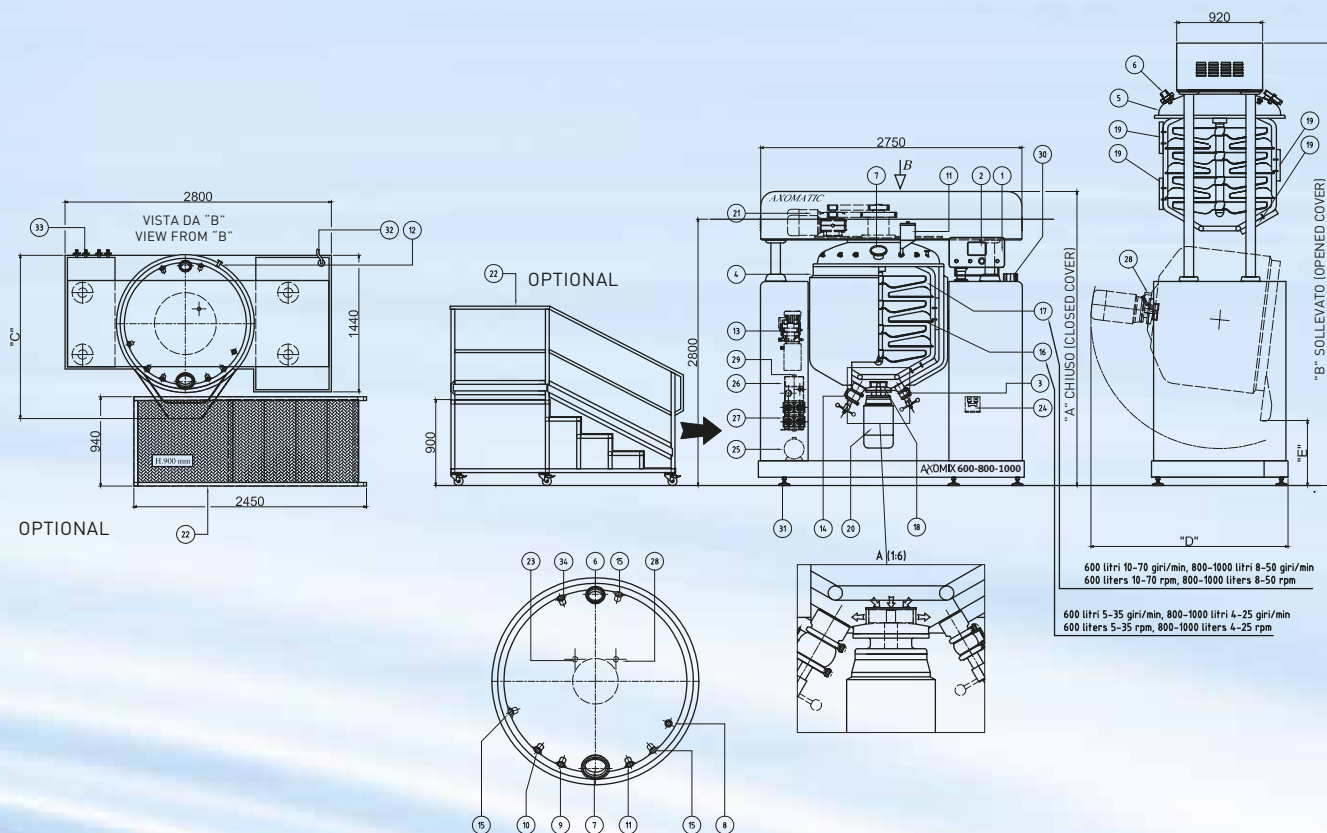

AXOMIX 600-800-1000

- | | | |
|---|----|--|
| Pannello di comando | 1 | Control panel |
| Touch screen per le funzioni della macchina | 2 | Touch-screen display for machine functions |
| Valvola 1 1/2" di carico prodotto (optional) | 3 | Product charge valve 1 1/2" (optional) |
| Recipiente prodotto | 4 | Vessel |
| Coperchio | 5 | Cover |
| Lampada per illuminazione interna recipiente (dn100) | 6 | Light for internal illumination (dn100) |
| Specola con tergcristallo per ispezione recipiente (dn200) | 7 | Inspection glass with whiper (dn200) |
| Attacco per vuoto sul coperchio (t.c. 1 1/2") | 8 | Vacuum connection on the cover (t.c. 1 1/2") |
| Attacco per aspirazione polveri dall'alto (t.c. 1 1/2") | 9 | Powder connection on the cover (t.c. 1 1/2") |
| Attacco per aspirazione liquidi dall'alto (t.c. 1 1/2") | 10 | Liquid connection on the cover (t.c. 1 1/2") |
| Tramoggina essenze (t.c. 3/4") | 11 | Small hopper for additive, parfumes etc. (t.c. 3/4") |
| Scarico acqua | 12 | Water discharge |
| Centralina per ribaltamento e sollevamento oleodinamici | 13 | Oil pump for vessel tilting and cover lifting |
| Valvola 2 1/2" di scarico prodotto (optional) | 14 | Product discharge valve 2 1/2" (optional) |
| Sfera di lavaggio sul coperchio (optional) (t.c. 1 1/2") | 15 | Cover sprayball (optional) (t.c. 1 1/2") |
| Pale mescolazione lenta | 16 | Counter-rotating blades agitator |
| Pale mescolazione veloce | 17 | Rotating blades agitator |
| Turbina motorizzata da sottoldo 300 a 3000 giri/min | 18 | Turbine driven from bottom (from 300 to 3000 rpm) |
| Raschianti | 19 | Scrapers (ptfe made) |
| Motore turbina | 20 | Turbine motor |
| n.2 Motoriduttori mescolazione | 21 | N. 2 Motor reduction gears for slow mixing |
| Passerella con scala su rotelle per operatore (optional) | 22 | Operator catwalk with stairs and wheels (optional) |
| Sfera di lavaggio sul fondo del recipiente (optional) (t.c. 3/4") | 23 | Vessel sprayball (optional) (t.c. 3/4") |
| Pompa del vuoto ad anello liquido | 24 | Water ring vacuum pump |
| Pompa per ricircolo acqua (inox) | 25 | Water recirculation pump (stainless steel) |
| Bacinella porta resistenze per riscaldamento prodotto | 26 | Water tank for heating system |
| Resistenze riscaldamento acqua | 27 | Heating elements |
| Sonda temperatura prodotto | 28 | Probe product temperature control |
| Sonda temperatura acqua | 29 | Probe water temperature control |
| Indicatore allarmi macchina | 30 | Light for machine alarms |
| Piedi regolabili | 31 | Foot silent block |
| Cavo per connessione elettrica | 32 | Electric connection cable |
| Connessioni idrauliche | 33 | Water connections |
| Connessione trasduttore vuoto | 34 | Vacuum transductor |

CONSUMO ACQUA PER POMPA DEL VUOTO / WATER CONSUMPTION FOR VACUUM PUMP

POTENZA INSTALLATA / INSTALLED POWER

MOTORE TURBINA DA SOTTO / MOTORS OF TURBINE FROM BOTTOM

MOTORI MESCOLAZIONE / MOTORS FOR SLOW MIXING

CENTRALINA OLEODINAMICA / OIL PUMP FOR TILTING AND LIFTING

POMPA DEL VUOTO / VACUUM PUMP

RESISTENZE RISCALDAMENTO / HEATING ELEMENT

POMPA DELL'ACQUA / WATER RECIRCULATION PUMP

2 - 4 L. / min a 1 bar / 2 - 4 L. / min at 1 bar

86 kW - 165 A - 400 V - 50 Hz - 3+T/G+N - 50mm²

22,0 kW

2 x 4,0 kW

1,1 kW

4 kW

32,0 kW

0.37 kW

	"A"	"B"	"C"	"D"	"E"
AXOMIX 600 Lt	2800	3950	1570	1900	430
AXOMIX 800 Lt	3080	4380	1620	2000	660
AXOMIX 1000 Lt	3160	4560	1670	2045	600



ALTINIGG



AXOMATIC[®] group

TUBE FILLING, CARTONING AND PROCESS SOLUTIONS

STABILIMENTO E UFFICI:

VIA EINSTEIN, 8 - I-20019 SETTIMO MILANESE (MI) - ITALY

TEL. +39-02-328.53.70 - FAX +39-02-335.02.894

E-mail: sales@axomatic.com - Web site: www.axomatic.com

Skype: [axomatic.sales](https://www.skype.com/name/axomatic.sales)

Diritti riservati a termine di legge - Riproduzione anche parziale vietata

