



**AXOMIX**

**100-300**



**AXOMATIC<sup>®</sup>**  
group

**TUBE FILLING, CARTONING AND PROCESS SOLUTIONS**



AXOMATIC Filling and Process Solutions leader da sempre nel settore delle macchine intubatrici, mescolatori sottovuoto e macchine di processo è presente sui più competitivi mercati mondiali ed ha macchine installate nelle più importanti società cosmetiche, farmaceutiche ed alimentari.

Premiata dal costante successo dei propri prodotti, dotati delle più avanzate tecnologie, quali anticipatori di domande sempre più sensibili ai contenuti dell'innovazione e della semplicità di utilizzo e cambio di formato.

Il servizio post vendita qualifica anche sotto il profilo commerciale, l'eccellenza della società Axomatic, verso il cliente.



Axomatic has always been a leader in the filling and process solution sector, is present in the most competitive and important world markets and its machines are installed in the most important cosmetic, pharmaceutical and food industries.

The company is proud of the constant success of its product, which are equipped with the most advanced technology and anticipate increasingly more detailed requests concerning innovation.

Even under the sales profile, the after-sales service is proof of the excellent service that Axomatic gives its clients.



AXOMATIC Filling and Process Solutions war schon immer eines der führenden Unternehmen im Bereich der Tubenfüll - und -verschleißmaschinen sowie der Misch - und Homogenisieretechnik. Die AXOMATIC Maschinen sind auf allen wichtigsten Weltmärkten in der kosmetischen, pharmazeutischen, chemischen und Nahrungsmittelindustrie im Einsatz und durch ihr attraktives Preis-/Leistungsverhältnis ueberaus konkurrenzfaehig.

AXOMATIC ist durch die konstante Qualität und Zuverlässigkeit seiner Produkte geprägt, die stets über modernste Technologien verfügen und bei denen auf Innovation größten Wert gelegt wird. So ist man bei AXOMATIC auch stets bereit, auf Sonderwünsche des Kunden einzugehen.

Ein weiterer wesentlicher Punkt, den man bei AXOMATIC nie außer acht gelassen hat, ist der Kundenservice, der durch ein weltweites Netz von Vertretungen und Servicetechnikern gewährleistet wird.

# AXOMIX

## 100-300



**Axomix con turbina  
azionata dall'alto**  
Axomix with top  
driven turbine

## Axomix con turbina azionata dal basso

Axomix with bottom driven turbine



- Fusori da 5 lt. a 2000 lt.
- Pre-melters from 5 up to 2000 lt.



- Pale contro-rotanti
- Contra-rotating blades

## Axomix con turbina azionata dal basso e ricircolo del prodotto

Axomix with bottom driven turbine and external product recirculation



- Valvole per carico / scarico prodotto
- Valves for product suction and discharge



- Turbina rotore statore
- Turbine rotor stator

## Axomix con turbina azionata dal basso Axomix with bottom driven turbine

## Axomix con turbina azionata dall'alto Axomix with top driven turbine

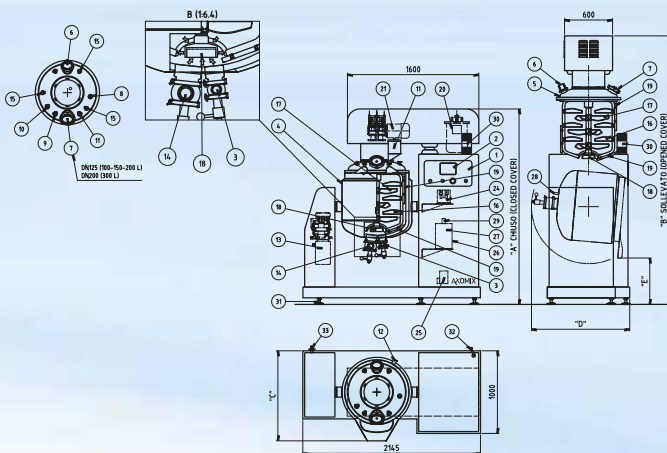
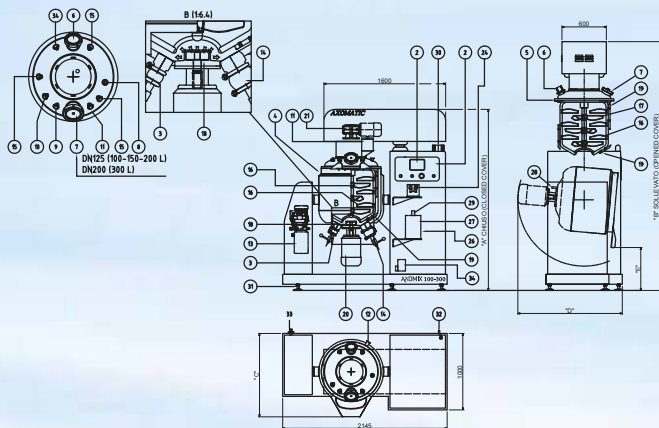

# AXOMIX 100-300

- |   |    |  |
|---|----|--|
| Pannello di comando                                     | 1  | Control panel                                      |
| Touch screen per le funzioni della macchina             | 2  | Touch-screen display for machine functions         |
| Valvola 1 1/2" di carico prodotto (Optional)            | 3  | Product charge valve 1 1/2" (Optional)             |
| Recipiente prodotto                                     | 4  | Vessel   |
| Coperchio   | 5  | Cover  |
| Lampada per illuminazione interna recipiente (dn100)    | 6  | Light for internal illumination (dn100)            |
| Specola con tergitristallo per ispezione recipiente     | 7  | Inspection glass with whiper                       |
| Attacco per vuoto sul coperchio (t.c. 1")               | 8  | Vacuum connection on the cover (t.c. 1")           |
| Attacco per aspirazione polveri dall'alto (t.c. 1")     | 9  | Powder connection on the cover (t.c. 1")           |
| Attacco per aspirazione liquidi dall'alto (t.c. 1")     | 10 | Liquid connection on the cover (t.c. 1")           |
| Tramoggina essenze (t.c. 1")                            | 11 | Small hopper for additive, parfumes etc. (t.c. 1") |
| Scarico acqua   | 12 | Water discharge                                    |
| Centralina per ribaltamento e sollevamento oleodinamici | 13 | Oil pump for vessel tilting and cover lifting      |
| Valvola 2 1/2" di scarico prodotto (optional)           | 14 | Product discharge valve 2 1/2" (optional)          |
| Sfera di lavaggio (optional) (t.c. 3/4")                | 15 | Sprayball (optional) (t.c. 1")                     |
| Pale mescolazione lenta da 5 a 35 giri/min              | 16 | Counter-rotating blades agitator 3-35 rpm          |
| Pale mescolazione veloce da 10 a 70 giri/min            | 17 | Rotating blades agitator 10-70 rpm                 |
| Turbina da 300 a 3000 giri/min                          | 18 | Turbine for fast agitator 300-3000 rpm             |
| Raschianti  | 19 | Scrapers (ptfe made)                               |
| Motore turbina  | 20 | Turbine motor                                      |
| Motoriduttore mescolazione                              | 21 | Motor reduction gear for slow mixing               |
|   | 22 |  |
|   | 23 |  |
| Pompa del vuoto ad anello liquido                       | 24 | Water ring vacuum pump                             |
| Pompa per ricircolo acqua (inox)                        | 25 | Water recirculation pump (stainless steel)         |
| Bacinella porta resistenze per riscaldamento prodotto   | 26 | Water tank for heating system                      |
| Resistenze riscaldamento acqua                          | 27 | Heating elements                                   |
| Sonda temperatura prodotto                              | 28 | Probe product temperature control                  |
| Sonda temperatura acqua                                 | 29 | Probe water temperature control                    |
| Indicatore allarmi macchina                             | 30 | Light for machine alarms                           |
| Piedi regolabili  | 31 | Foot silent block                                  |
| Cavo per connessione elettrica                          | 32 | Electric connection cable                          |
| Rubinetto per connessione idraulica                     | 33 | Water connection                                   |

CONSUMO ACQUA PER POMPA DEL VUOTO / WATER CONSUMPTION FOR VACUUM PUMP  
 POTENZA INSTALLATA / INSTALLED POWER:  
 MOTORE MESCOLAZIONE / MOTOR FOR SLOW MIXING  
 MOTORE TURBINA / TURBINE MOTOR  
 CENTRALINA OLEODINAMICA / OIL PUMP FR TILTING AND LIFTING  
 POMPA DEL VUOTO / VACUUM PUMP  
 RESISTENZE RISCALDAMENTO / HEATING ELEMENT  
 POMPA DELL'ACQUA / WATER RECIRCULATION PUMP

### 300 L

2-4 L/min a/at 1 Bar  
 42 kW - 80 A - 400 V - 50 Hz  
 3,0 kW  
 9,3 kW  
 0,55 kW  
 2,2 kW  
 16,0 kW  
 0,37 kW

### 100-150-200-250 L

2-4 L/min a/at 1 Bar  
 35 kW - 66 A - 400 V - 50 Hz  
 3,0 kW  
 5,5 kW  
 0,55 kW  
 2,2 kW  
 16,0 kW  
 0,37 kW

	"A"	"B"	"C"	"D"	"E"
AXOMIX 100 Lt	2345	3015	1015	1290	740
AXOMIX 150 Lt	2420	3190	1065	1270	600
AXOMIX 200 Lt	2420	3260	1090	1320	560
AXOMIX 250 Lt	2500	3400	1120	1335	520
AXOMIX 300 Lt	2560	3510	1145	1350	510



**TUBE FILLING, CARTONING AND PROCESS SOLUTIONS**

**STABILIMENTO E UFFICI:**

VIA EINSTEIN, 8 - I-20019 SETTIMO MILANESE (MI) - ITALY

TEL. +39-02-328.53.70 - FAX +39-02-335.02.894

E-mail: [sales@axomatic.com](mailto:sales@axomatic.com) - Web site: [www.axomatic.com](http://www.axomatic.com)

Skype: [axomatic.sales](https://www.skype.com/name/axomatic.sales)

Diritti riservati a termine di legge - Riproduzione anche parziale vietata

